



X-HEAT[®]
Space Heating Technology



TECHNICAL DATA
Nano-Heat[®]

ABOUT YOUR NANO-HEATER

Nano-Heat is a reliable source of heat where natural gas or propane is being used, there is no flame and the surface of the heater operates below the ignition temperature of both fuels. Infrared heat is produced by the heaters and is absorbed by organic objects within range. All heaters are produced to provide safe flameless heat and tested for performance before being dispatched.

Plug & Play

Nano-Heat is supplied pre-wired with only a 5amp fused spur supply required. Simply terminate live neutral and earth and your nano-heater is ready to use. A industry standard 1/2" gas connection is supplied with the heater.

APPLICATIONS FOR USE:



Warehousing



Train Stations



Livestock Sheds



Assembly Areas



Welding Bays



Machine Shops



Sports Halls



Museums

THE SPECTRUM

Interest in infrared energy as an industrial tool has increased in recent years with many new and unusual applications. Infrared energy like light is electromagnetic wave energy, that travels in straight lines at 186,000 miles per second, casts shadows, may be transmitted, absorbed or reflected by matter, may be focused or dispersed by lenses or prisms of proper material, in fact it has many of the same properties as light waves except it has a longer wave length.

Nano-Heat produces a longer wavelength and is farthest from light, it is more easily absorbed by people, Nano-Heat is a low intensity far infrared emitter they are excellent for heating at a much lower cost than conventional combustion applications.

TYPES OF ELECTROMAGNETIC RADIATION

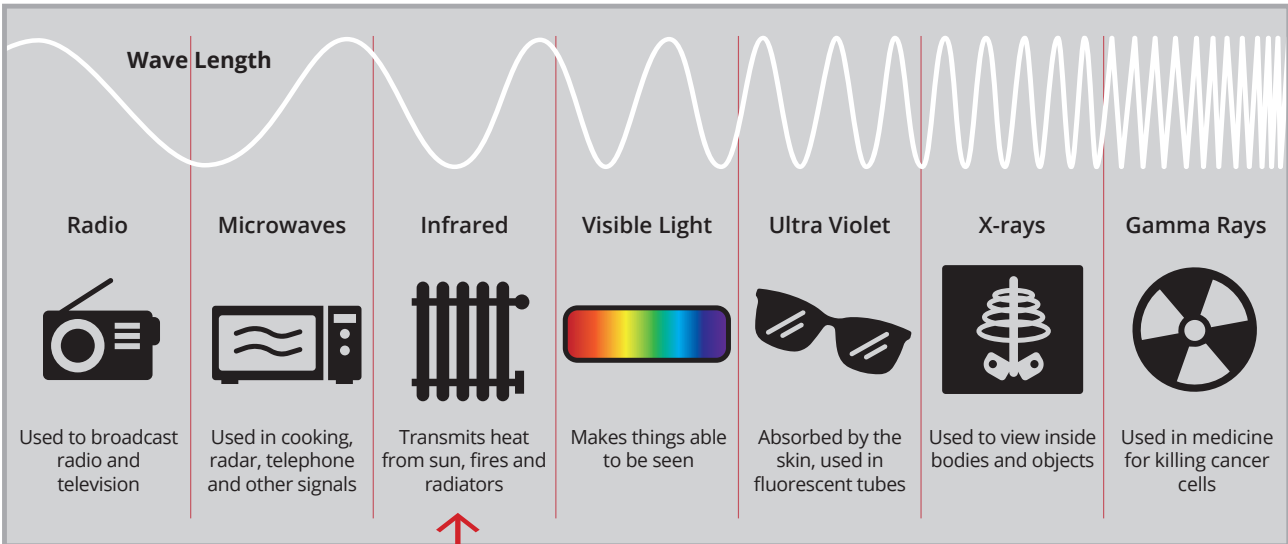

HOW IT WORKS?

1. Fuel enters the rear of the heater which is a gas tight stainless steel pan.
2. The fuel is dispersed by means of a dispersion tube which assists this process.
3. The fuel passes through a fabric pad which acts as both an insulator but also aids dispersion of the gas acting in resistance on the flow.
4. Fuel then comes into contact with the support bed i.e. Catalytic pad which is pre heated to the desired temperature by the internal heating element.
5. Oxidation occurs when the fuel and oxygen from the surrounding air meet within the support bed. The support bed has two levels of protection firstly a fibre scrim and secondly a wire mesh which are both held in place by a gas tight stainless steel trim.

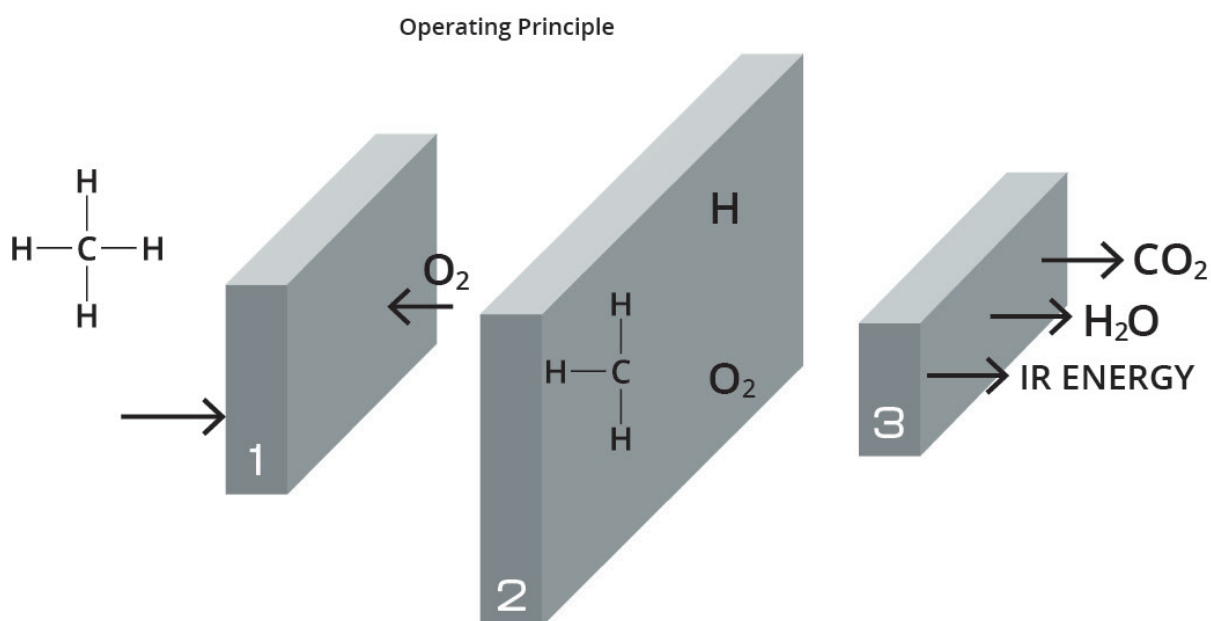

As can be seen the underlying principle of operation relies on heating of a body (the support) which then emits the stored energy as radiation at an appropriate wavelength. To proceed further, a brief discussion of radiant heat emissivity is required.

RADIANT HEAT

Radiant heat, also known as thermal radiation, is the transfer of electromagnetic energy which describes the heat exchange of energy by photons. Radiant heat is a mechanism for heat transfer which does not require a medium in which to propagate.

Radiant body emissions are normally discussed in terms of black body radiation. As the temperature of the body increases the body remains in thermodynamic equilibrium meaning that the energy absorbed is balanced by that emitted and the wavelength and amount of energy emitted to maintain this equilibrium. The peak wavelength of the emitted radiation can be calculated using Wien's displacement law. This shows that as the body temperature increases, the wavelength decreases. Table 1 gives the wavelength associated with different temperatures for black body radiation.

For radiation to be absorbed by people, the radiation needs to be at mid to long wavelength infrared.

Table 1: Association of IR wavelengths with different temperatures for black body radiation (Leading Infrared Heater Manufacturers and Suppliers, 2021)

Region	Abbreviation	Wavelength (µm)	Frequency (THz)	Photo Energy (meV)	Temperature Range (°C)
Near-infrared	NIR	0.75 - 1.4	214 - 400	886 - 1653	3,591 - 1,797
Short-wavelength Infrared	SWIR	1.4 - 3	100 - 214	413 - 886	1,797 - 693
Mid-wavelength Infrared	MWIR	3 - 8	37 - 100	155 - 413	693 - 89
Long-wavelength Infrared	LWIR	8 - 15	20 - 37	83 - 155	89 - -80 (Negative temperature)
Far infrared	FIR	15 - 1000	0.3 - 20	1.2 - 83	-80.15 - -270.15

HEAT MAP

Heat on floor in relation to distance.
Nano-Heat 10 kW

Position apparatus Pt (0;0)
Installation height = 2.5m
Inclination = 30°

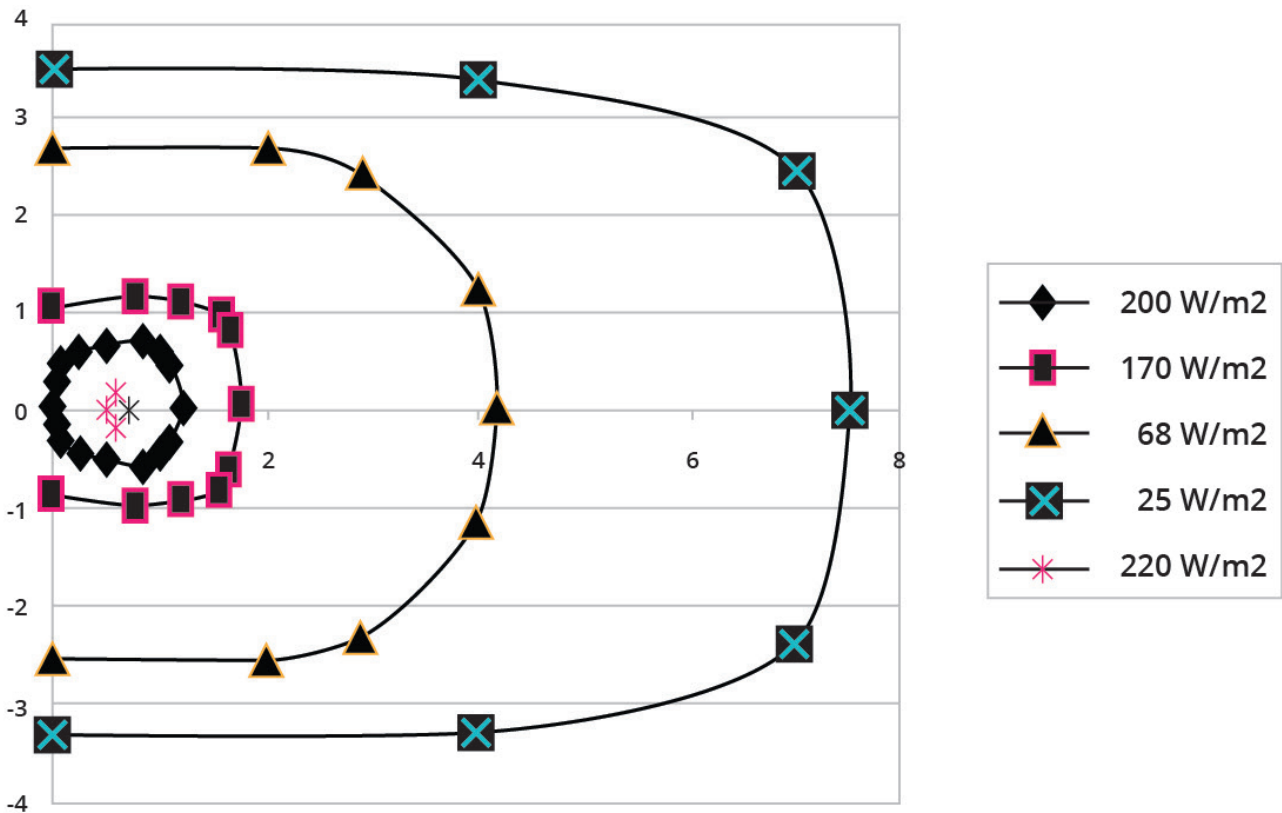

*Measured with flux metre

HYDROCARBON FUEL CRITERIA

Natural Gas – G20 at 20mbar supply pressure (appliance cat 2H)

Maximum supply pressure (Pmax)	25mbar
Minimum supply pressure (Pmin)	20mbar
Gas connection	½"

Propane – G31 at 37mbar supply pressure (appliance cat 3P)

Maximum supply pressure (Pmax)	37mbar
Minimum supply pressure (Pmin)	18mbar
Gas connection	½"

SAFETY CONTROLS

1. Low temperature sensor will activate if the temperature of the catalyst falls below the minimum operational temperature immediately de-energising the gas valve and going into cool down mode.
2. Over heat sensor will activate if the internal ambient temperature rises above the maximum threshold resulting in an over temperature fault. Gas valve and pre heat element will immediately de-energise putting the system into cool down mode.
3. The fan has a built in thermal overload switch which if activated will de energise the gas valve and pre heat element signalling fan failure.

SERVICING TOOLS REQUIRED

- CO2 Air quality analyser
- TTL-232R-3V3-AJ jack cable
- Thermal imaging camera
- Manometer
- 5mm spanner
- 8mm spanner
- Philips screw driver
- 3mm flat head screw driver
- 2 x adjustable spanner
- Soft brush 1"

TECHNICAL ENERGY SPECIFICATION

	NG	LPG
Heat Input	6 - 10 kW	6 - 10 kW
Appliance Type	A3	A3
Appliance Cat.	2H G20	3P G31
Dimensions	620 x 720 x 140	620 x 720 x 140
Weight	18kg	18kg
Gas Ps mb	7-13mb	18-37mb
Gas Connection	½"	½"
Wh Running	125w	125w
Volts	240	240
Consumption	0.69 - 0.95	0.45 - 0.76kg/hr
Co2 %	0.5% - 2%	0.5% - 2%
NOx	0% / PPM	0% / PPM
CO	0% / PPM	0% / PPM

VENTILATION

The surface of the catalyst requires at least 10m³/hr air per kW (Zero carbon monoxide and zero Nitrous oxides are produced) This reaction produces three by products they are heat, trace water and trace carbon dioxide. No flu is required to operate this appliance.

INSTALLATION CRITERIA

Nano-Heat has been designed as a zonal heater to heat people. Installation of this unit can be mounted to any structurally sound wall at heights of 2.5m – 3.5m from the ground at an angle of 20° - 30°. The unit can be wall mounted using the bracket provided as in the diagram below.

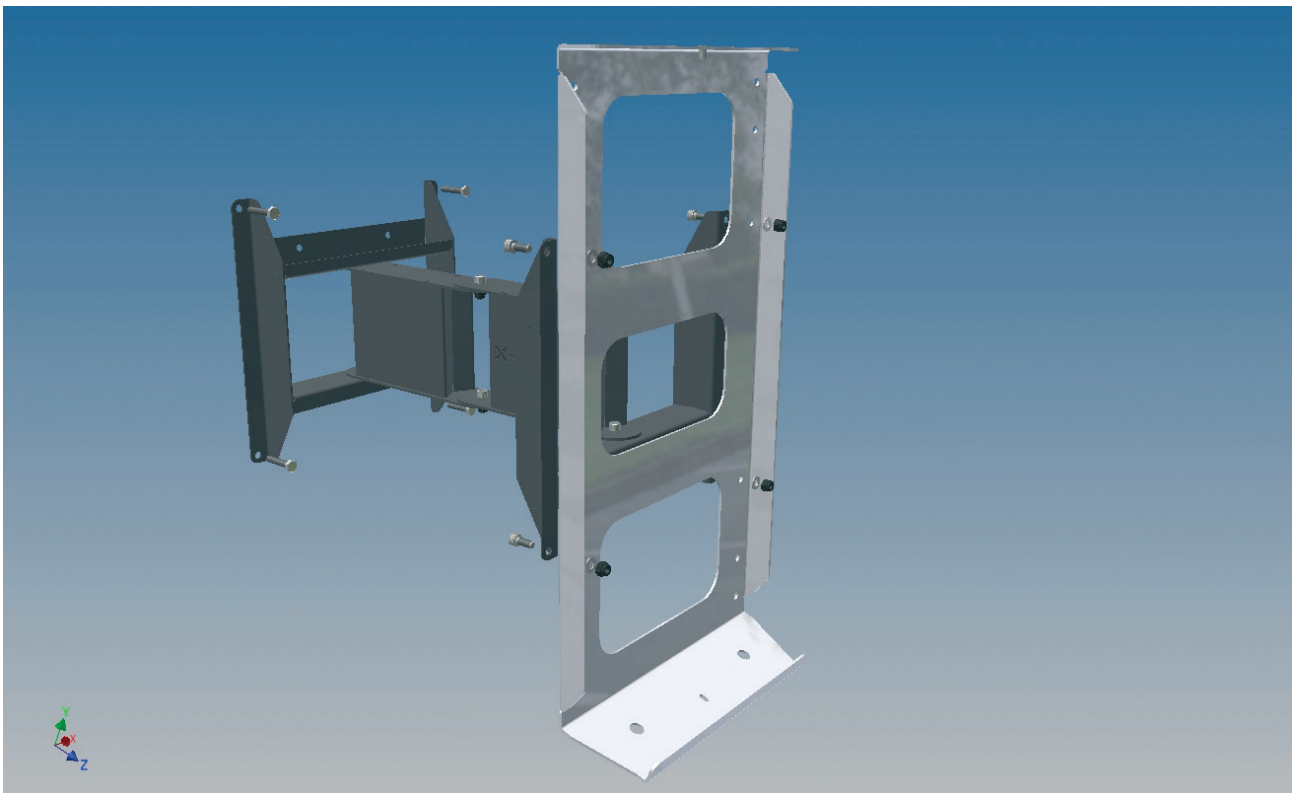
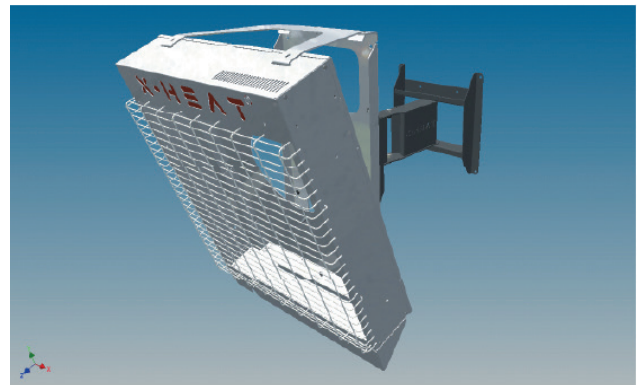
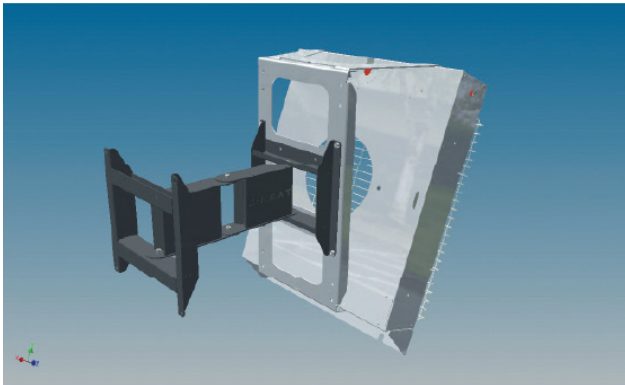

INSTALLATION CRITERIA

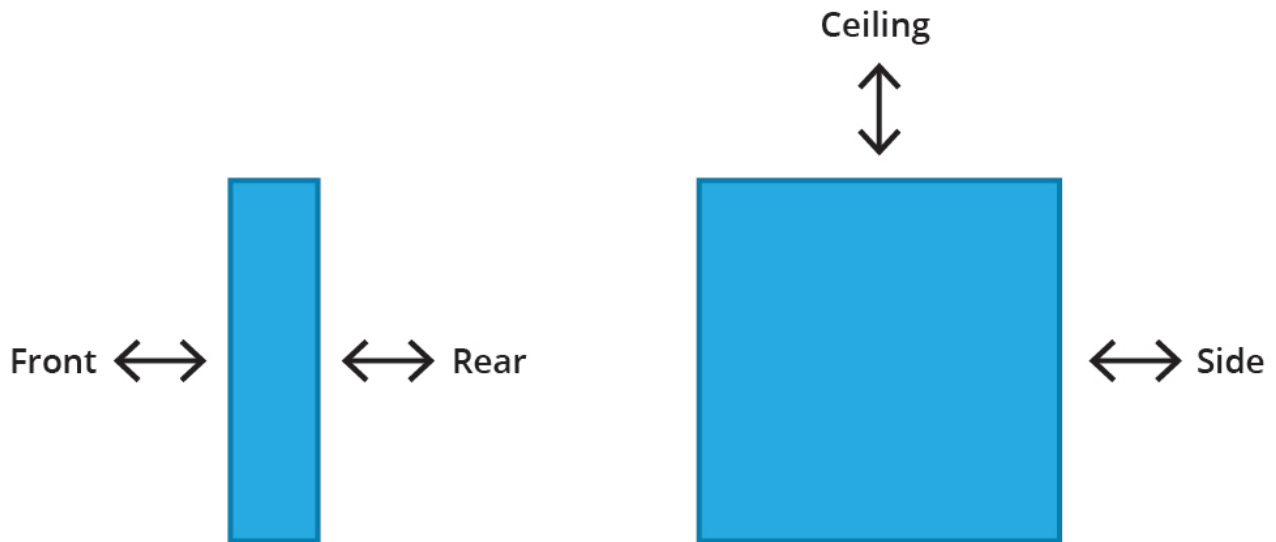

	Front	Rear	Ceiling	Side
Nano-Heat 10kW	600mm	100mm	*300mm	300mm

**Minimum clearance to combustible materials with a stainless steel reflector fitted.*

USEFUL TECHNICAL INFORMATION

- Nano-Heat provides a safety factor that can not be obtained with a flame, lamps, or tubes. Direct heating by flame in the presence of any combustible materials is unthinkable.
- Nano-Heat emits infrared energy meaning they heat people and not air , you realise a much faster sensible heat gain.
- Nano-Heat operate without leaving the carbon deposits normally associated with combustion equipment meaning lower servicing costs.
- Due to the low energy requirements nano-heat provides a significantly shorter payback time
- Nano-Heat operates silently, reducing noise pollution improving the working environment.
- Nano-Heat systems are thermostatically controlled for space heating applications providing greater energy savings
- Research shows that medium to long wave infrared heat can improve the wellbeing of people increasing blood flow and reducing aches and pains
- All of X-Heats products must pass rigid inspection to assure quality and performance is maintained as well the highest standard of safety
- Nano-Heat is the result of extensive laboratory and field testing all products are designed according to strict engineering requirements.

OXIDATION ANALYSIS

Figure 1 represents the reaction profile of pure methane in the presence of air over the catalytic bed. Conversion of methane started around 253°C (light-off temperature) and can be confirmed by the rise in carbon dioxide (CO₂) and water (H₂O) in the spectra below. This trend of gentle rise in conversion persisted till the temperature of the bed reached approximately 400°C, after which a sharp increase in conversion of methane appeared. Finally, complete conversion of methane was noted at an upper bed temperature of 510°C, after which a significant exotherm (up to 580°C) resulted due to the complete conversion of carbonaceous components into carbon dioxide (CO₂). GC analysis confirmed clearly that there was no carbon monoxide (CO) formed under all the conditions of methane (CH₄) conversion.

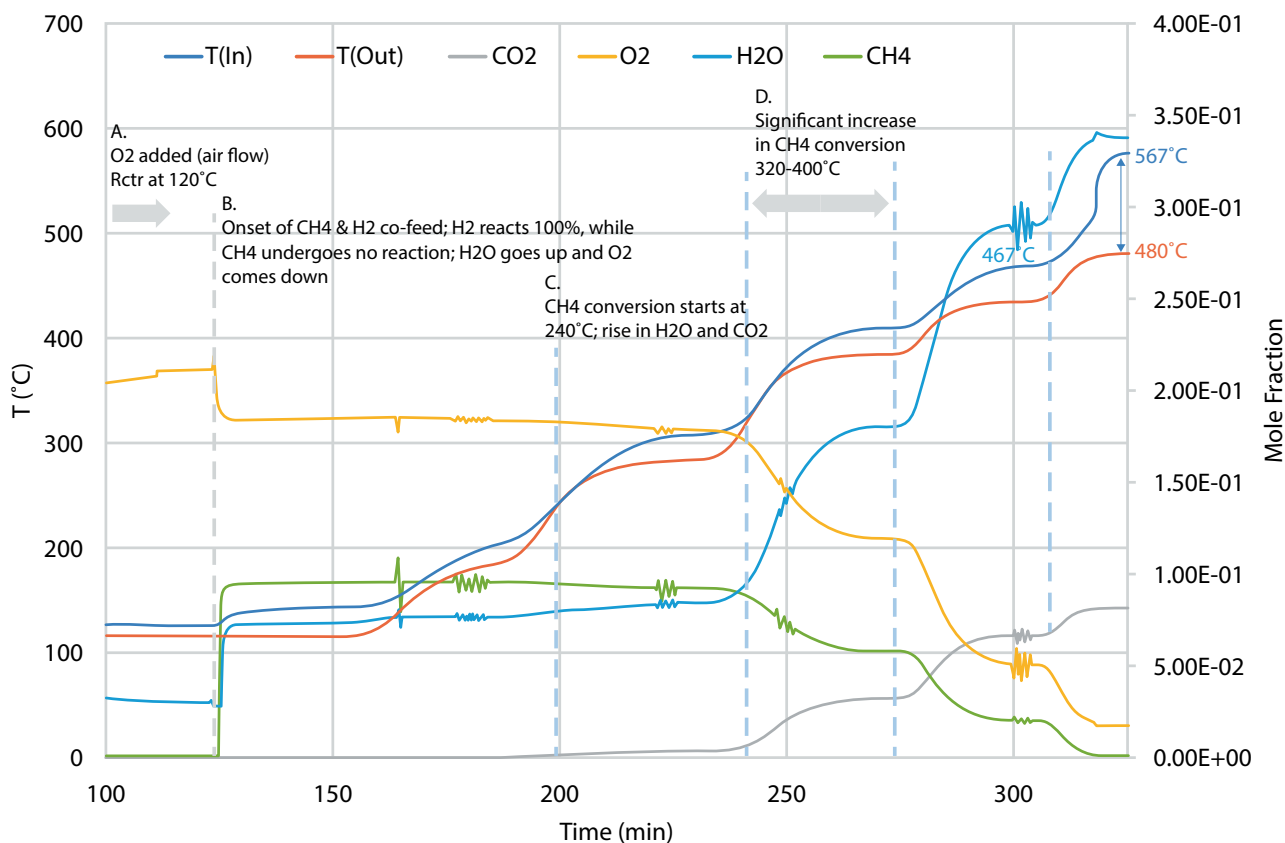
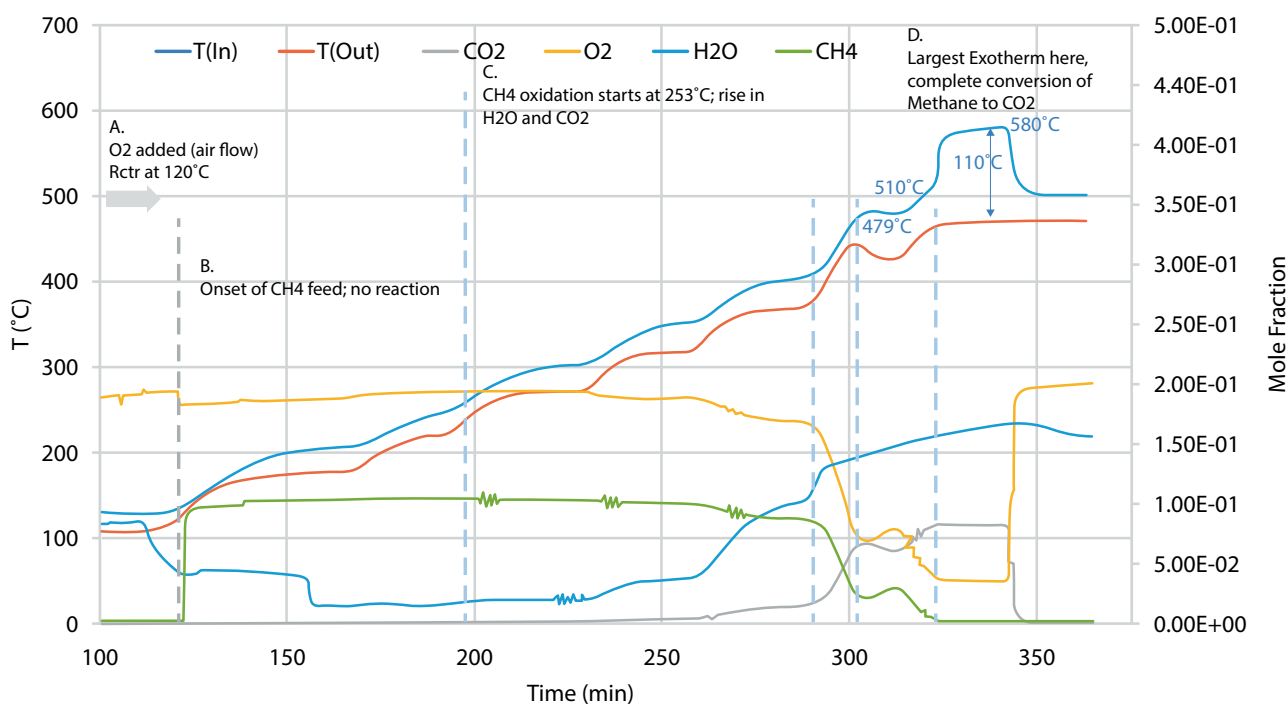

Figure 2 is the reaction profile for a mixed gas stream with 25% hydrogen addition (with 75% methane). Initially the reactor was maintained at 120 °C and a space velocity of 11.55 per minute was used for this run of experiments. It was observed that hydrogen upon its introduction to the reactor at point B (observed in Figure 2), instantly reacted with oxygen from the air, resulting in a production of H₂O. However, no methane conversion was spotted until bed temperature reached 240 °C (light off temperature), as measured by the onset of CO₂ evolution. A significant methane conversion occurred in the 320-400 °C range, which continued up to 506 °C when a complete conversion of methane into CO₂ was observed. Another significant observation was made regarding the light off temperature of methane – it did not show any noticeable increase, due to inclusion of hydrogen in the feed stream.



FUTURE PROOFING TECHNOLOGY

The previous data explores the effects of varying feed ratios of hydrogen: methane (25-75%, 50-50%, 80-20%) in the study of the oxidation reaction with approximate air flows. In the ratio of 25-75 (H₂:CH₄), which is the region closely mirroring the expected levels of initial hydrogen injection into the natural gas feed supply as outlined by the government and net zero targets, there was no significant difference in light off characteristics between that for pure methane. The methane light off temperature was very similar, while hydrogen was instantaneously consumed. This is expected for hydrogen due to its high reactivity.

As the quantity of hydrogen is increased, to 50-50 and then to 80-20, the starting light-off temperature was observed to increase from around 250 °C (low H₂:CH₄ ratio, and pure methane condition to almost 320 °C for 50-50 and 360 °C for 80-20. There is evidence that preferential oxidation of hydrogen occurs with increased hydrogen partial pressures. However, 100% conversion of methane occurs only around 500 °C, even for pure methane. GC analysis also proved that there is no carbon monoxide (CO being formed in the experiments upon induction of methane (both pure and in mixture).

Think Green
HYDROGEN
ENERGY 



ANY QUESTIONS?

If you require any further information then please contact us, a member of the team will be happy to help.



X-HEAT[®]
Space Heating Technology

INFO@XHEAT.CO.UK | WWW.XHEAT.CO.UK

© 2022 X-HEAT LTD